

ES100

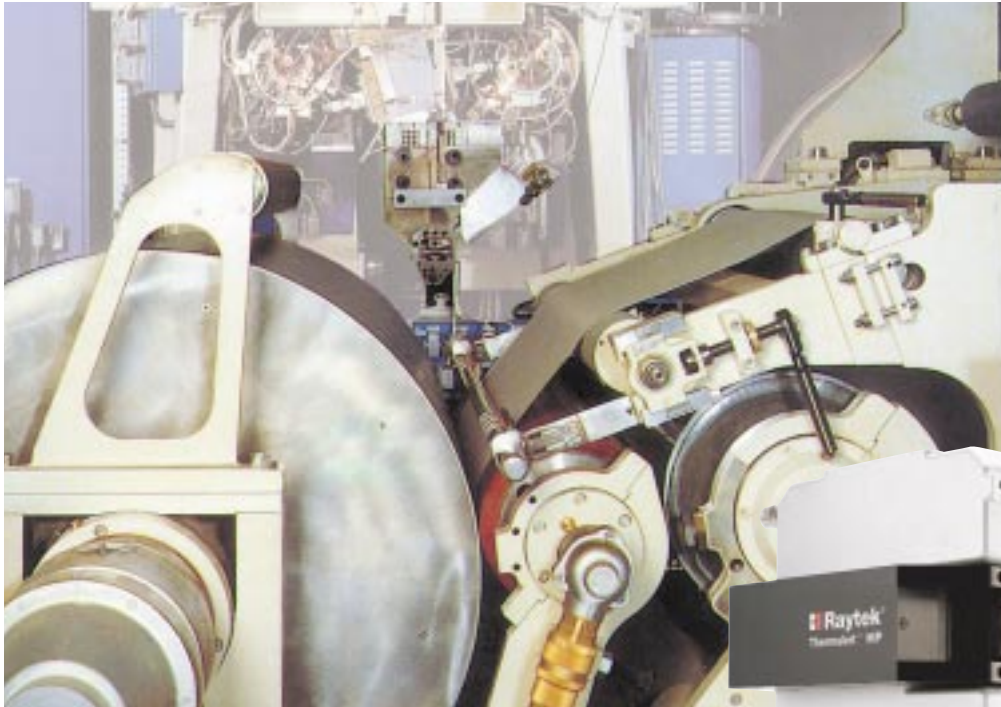

Plastic Sheet, Cast Film Extrusion and Other Web Processes



(Photo: Courtesy of EC Erdölchemie, Germany)

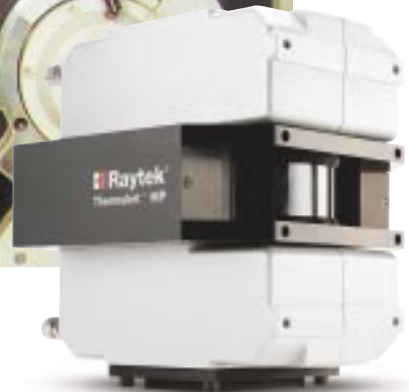

MP50™ Process Imager

MP50 Process Imager



The heart of the EC100 system is an MP50 Process Imager. The MP50 Process Imaging Series is a family of advanced infrared linescanners providing accurate, real-time, thermal imaging for a wide variety of industrial applications, including continuous sheet and web-based processes.

The MP50 is surprisingly easy to install.

Pre-wired cables allow for fast, easy installation and connection to a standard PC (Windows NT® or Windows 2000®). Many installations require less than an hour from start to finish. Versatile DataTemp® Software allows custom configuration of MP50 operating parameters and display of thermal images and temperature profiles. The MP50 is designed for reliability and continuous operation in harsh industrial environments. The MP50's rugged housing includes built-in provisions for water-cooling and air-purge.

Offering best-value performance, the MP50 is the most widely used linescanner worldwide.

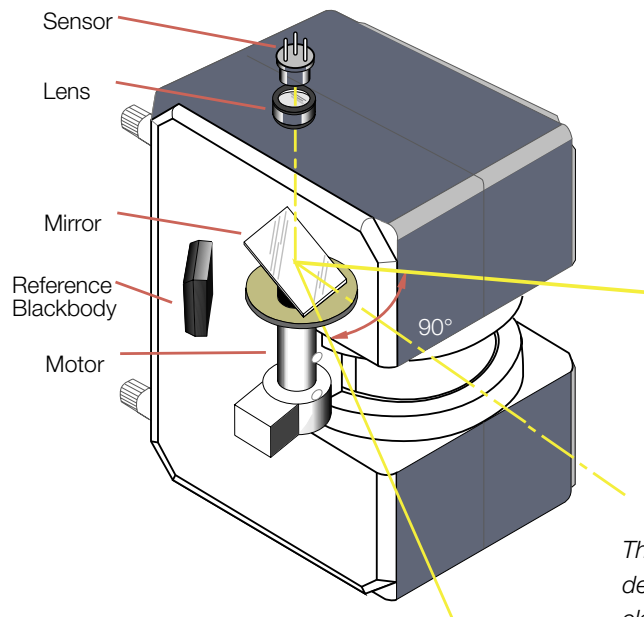

The MP50 contains the scanning mechanism, infrared detector, optics, signal processing electronics, electrical inputs/outputs, and data communications.

The most widely used solution for real-time process temperature imaging and analysis

- Fast scan speed up to 48 lines per second
- Real-time color thermal images
- Accurate data analysis
- Rugged, waterproof housing
- 40,000 MTB brushless scanning motor
- Field-replaceable window
- Models for specialized applications
- Two-way digital communications
- Built-in air purge and water cooling

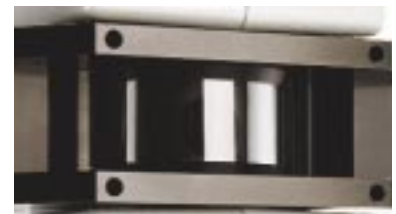

The MP50 features a rugged MICA window.



Extrusion Process Imaging System

The ES100 System is an automated inspection system for detecting, measuring, and classifying defects occurring in sheet extrusion, cast film and other continuous web processes.

Benefits

- Melt temperature profile for monitoring die bolt heaters
- Sheet temperature profile for more effective chill roll control
- Early detection of die bolt heater problems or plugged dies
- Faster grade changes and reduced setup time
- Automate quality monitoring
- Reduce scrap

Features

- Configure sectors for each die bolt heater
- Define product specific configurations and data files
- Analyze sector temperatures automatically
- Automatic fail-safe alarm logging
- Optional analog and digital outputs for each sector
- Software supports English, German, French, Finnish, and Italian languages

The ES100 Process Imaging System monitors flat die extrusion or other continuous web processes

The ES100 System provides an advanced capability for monitoring temperature distributions of plastic sheet and cast film extrusion. Using the MP50 Process Imager, the ES100 System offers the flexibility to define and configure measurement sectors for each die bolt to facilitate improved temperature monitoring.

Temperature Monitoring

The ES100 System provides the capability to define any number of sectors corresponding to specified areas across the sheet. Sectors are defined by name, location, and the desired processing of temperature data within the sector

(e.g., average, minimum, or maximum temperature). This capability is very useful in sheet and cast film extrusion processes where sectors can be configured to provide temperatures corresponding to each die bolt heater.

The ES100 system continuously monitors the extrusion process allowing temperature data to be visualized as a line graph (profile) and a thermographic image. Profiles and images may be printed or archived for future analysis.

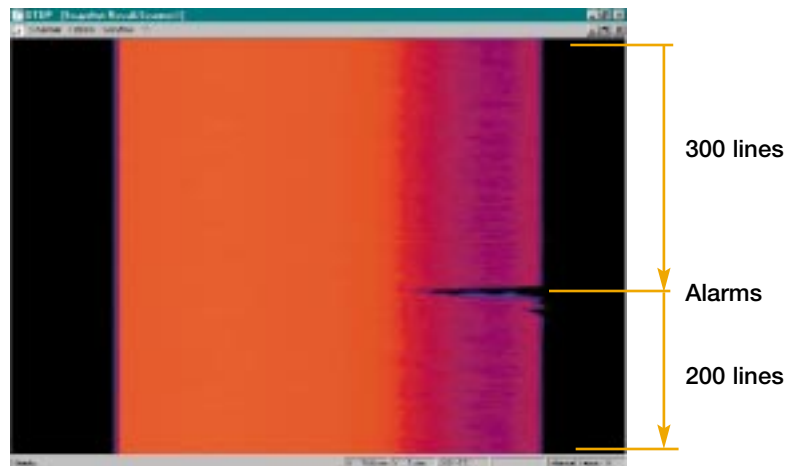
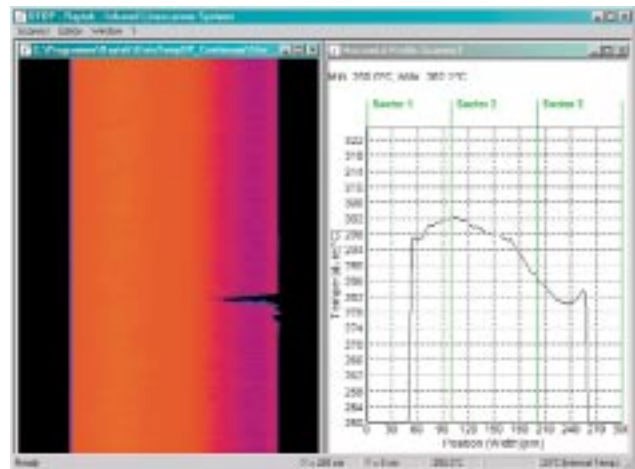

Alarm Documentation

In case of an alarm, information is automatically saved indicating the time, alarm duration, and the defect position. When an alarm "trigger" occurs, 500 temperature lines are automatically stored in an alarm log file.

The ES100 System features an easy-to-use “point and click” user interface

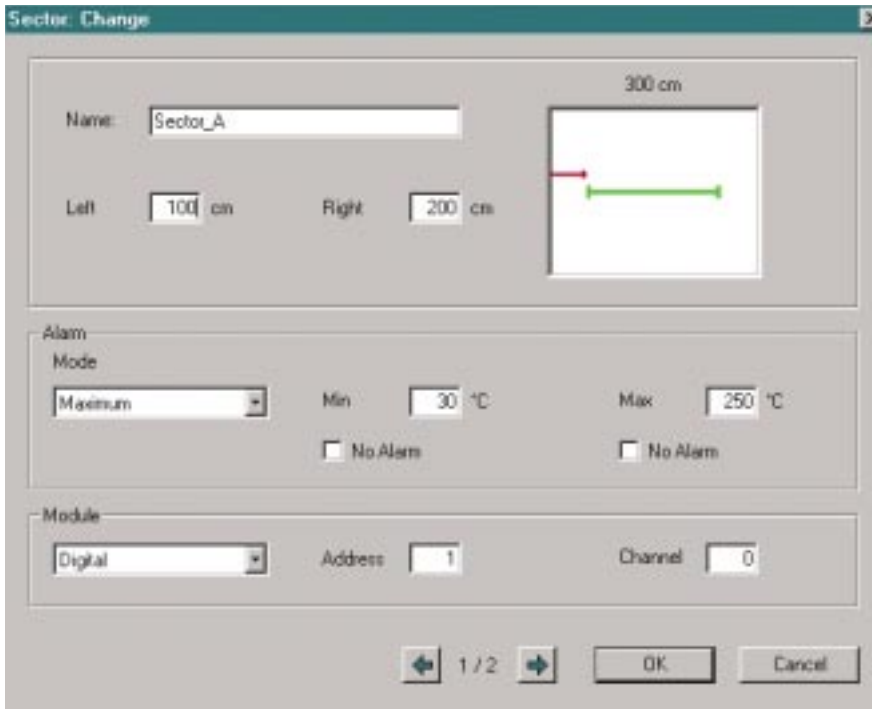

Sector Configuration Screen

The screen allows specification of sector name, size, location, temperature limits, signal processing, and optional Output Module configuration.

Custom Configurations

DataTemp ES100 Software allows custom configurations for any type of product.

General	Specify MP50 scan rate, PC COM ports, baud rate, and native language
Temperature	Adjust emissivity, minimum/maximum temperature, and temperature units
Geometry	Specify MP50 distance, installation angle, and thermal image dimensions, and units
Data File	Define product name, date and time stamp for storing images under alarm conditions, and data file storage path
Sector	Configure any number of sectors by width and location. Specify desired signal processing and alarm conditions for each sector.
Input/Output	Specify COM port, addresses, and channel numbers for optional Analog or Digital Output Modules, and output of sector results on a specified COM port

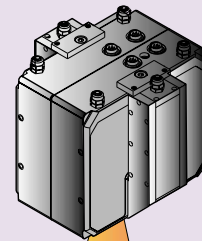

MP50

Processing Image

The MP50 Process Imager scans the surface of the extruded material and measures a line of 256 points using a rotating mirror that scans a 90° field-of-view up to 48 times per second. As the extruded sheet passes through the MP50's field-of-view, a two-dimensional thermal image or “thermogram” is formed. Thermal images are continuously displayed in real time as the sheet extrudes.

Quick Easy Installation

The MP50 installs easily—just like a camera—and views the sheet from above or below wherever it has a clear viewing path. Connecting the pre-wired cables (included) to a PC and entering installation dimensions in the ES100 Software completes the installation process.

The ES100 System offers unique capabilities for monitoring sheet extrusion, cast film, and other continuous web processes.

As illustrated below, the ES100 System continuously monitors the temperature distribution and temperature profile of the extruded melt for each die bolt allowing the quality and performance of the process to be continuously monitored.

Sheet Extrusion

Sheet extrusion is a continuous process where melted polymer is forced through a die to achieve the desired width and thickness. The extruded sheet should exhibit a relatively uniform temperature profile. An MP50 installed after the die continuously monitors the sheet temperature corresponding to each die bolt. This permits early detection of die bolt heater problems, plugged dies and allows for improved sheet thickness uniformity.

The calender strongly influences sheet quality. Calender roll temperature uniformity influences the quality of flat sheets and insures they are warp free. Non-uniform cooling conditions generate differences in sheet elongation and cause unwanted stresses to be molded-in. Installing an MP50 after the calender can help balance unsymmetrical temperature profiles. DataTemp ES100 software supports multiple MP50 Process Imagers.

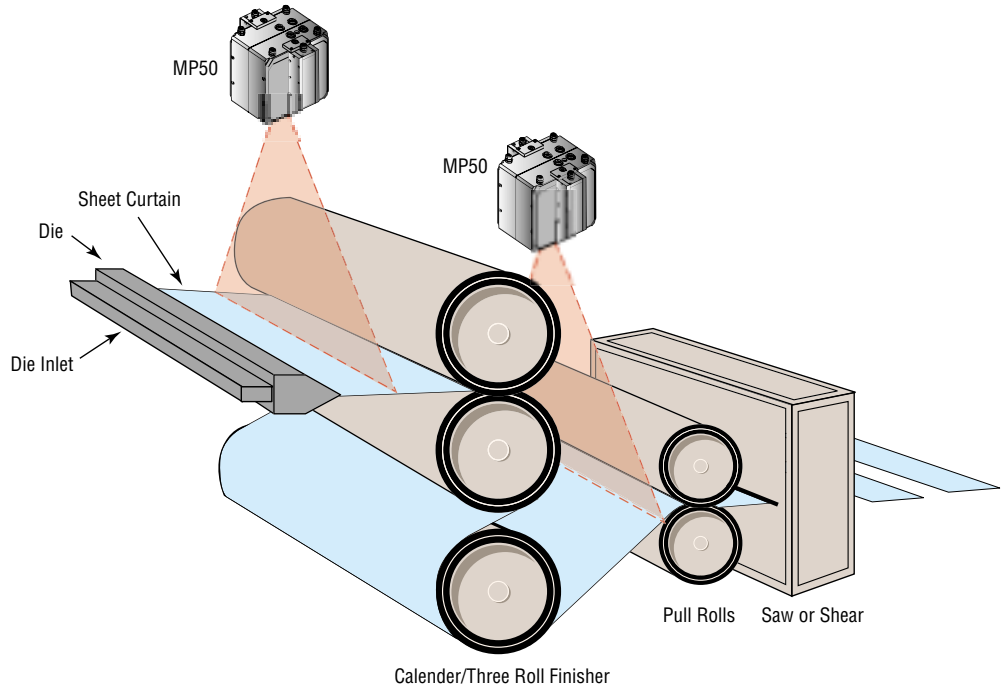

Cast Film Extrusion

The cast film process involves extrusion of polymer melt through flat die to form a thin, molten sheet or film. The film is "pinned" to the surface of a casting or chill roll (typically water-cooled and chrome-plated) by a blast of air from an air knife or vacuum box.

Installing the MP50 after the die continuously monitors the film temperature corresponding to each die bolt allowing for early detection of die bolt heater problems and plugged dies, resulting in improved thickness uniformity, and enhanced film surface finish.

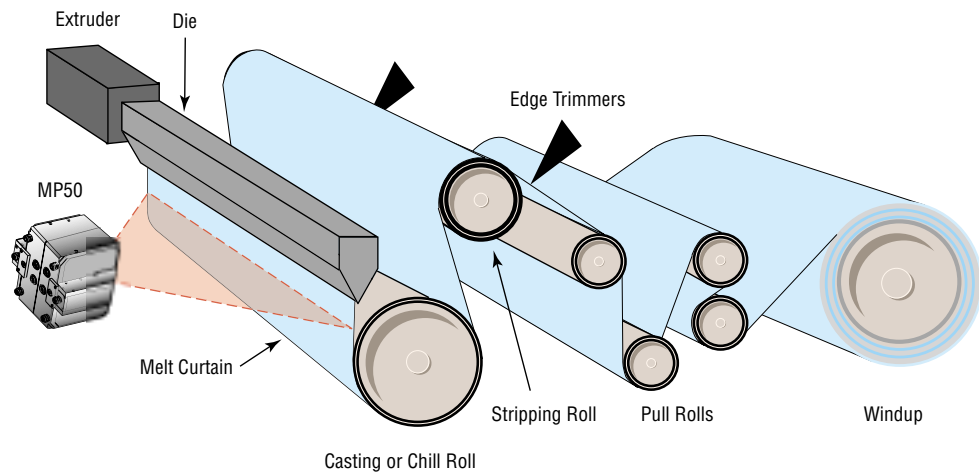

ES100 System

RAYTES100P31 MP50 Process Imager¹
 DataTemp ES100 Software
 DTMP Software
 Industrial power supply
 RS232/485 Converter

¹See MP50 Datasheet for other models.

ES100 Specifications

Temperature Range ²	100 to 350°C (212 to 662°F)
System Accuracy ²	±3°C (±6°F)
Optical Resolution ²	60:1 (90% energy)
Ambient Temperature	0 to 50°C (32 to 122°F)
Field of View (FOV)	45° or 90° (selectable)
Number of Temp. Points	256 (45° or 90° FOV)
Scan Rate	36 Hz (45° or 90° FOV) 48 Hz (90° FOV) ³
Physical Dimensions	200 x 180 x 190 mm (7.9 x 7.1 x 7.5 in)
Weight	7 kg (15.5 lbs)

² Specifications for MP50P31 (see MP50 Datasheet for specifications of other models). MP50 models available measure from 20°C (68°F) to in excess of 450°C (842°F).

³ Requires PC with 230 kBit/sec (or faster) serial interface.

Options and Accessories

Part Number	Description
XXXTMP50ACCC	MP50 carrying case
XXXTMP50AC485CB	RS485 cable extension
XXXTMP50ACPSCB	Power cable extension
XXXTMP50LS	Line laser sighting (option)
XXXMP50ACMP	Mounting plate for adjustable mounting base (or tripod)
XXXTMP50AMB	Adjustable mounting base
XXXSYS16DA	Digital Output Module (16 channel, open collector)
XXXSYS4AA	Analog Output Module (4 channel, mA or V)
XXXSYS485CV	RS232/RS485 Converter (needed for output modules)

Easy Installation

The small size of the MP50 Process Imager allows for easy installation. The MP50 connects to a standard PC operating Windows® NT4 or Windows® 2000. The system's RS485 digital interface insures reliable operation over long cable runs. The diagram below represents a typical system installation. Optional analog and digital (open collector) output modules operate from a second serial COM port on the PC. The PC never has to be opened to install the ES100 System.

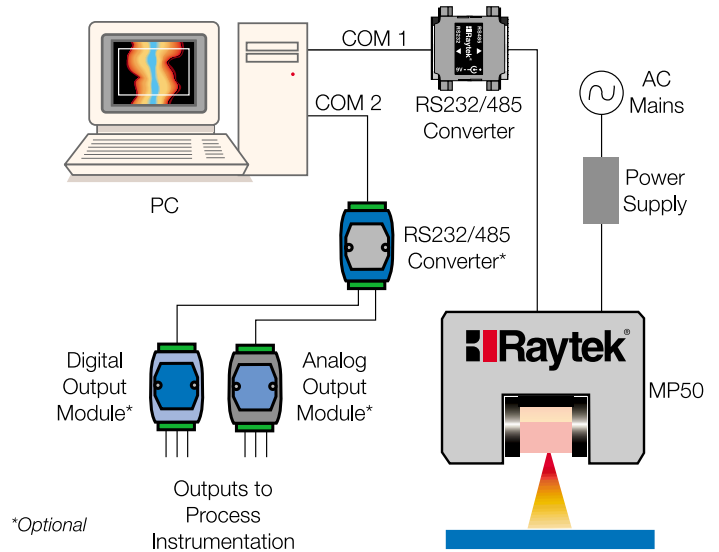

www.raytek.com

for up-to-the-minute features

Raytek Automation Products: Noncontact Temperature Measurement Solutions For Industrial ApplicationsSM

Worldwide Headquarters

Raytek Corporation
 Santa Cruz, CA USA
 Tel: 1 800 227 8074
 1 831 458 1110
 Fax: 1 831 458 1239
 automation@raytek.com

Raytek de Mexico, S.A. de C.V.

Puebla, Pue. Mexico
 Tel: 52 222 230 4380
 Fax: 52 222 230 4438
 ventas@raytek.com.mx

Raytek China Company

Beijing, China
 Tel: 86 10 64392255
 Fax: 86 10 64370285
 info@raytek.com.cn

Raytek Japan, Inc.

Osaka, Japan
 Tel: 81 6 4390 5015
 Fax: 81 6 4390 5016
 info@raytekjapan.co.jp

South American Headquarters

Raytek do Brasil
 Sorocaba, SP Brasil
 Tel: 55 15 32176046
 Fax: 55 15 32175694
 info@raytek.com.br

European Headquarters

Raytek GmbH
 Berlin, Germany
 Tel: 49 30 4 78 00 8 400
 Fax: 49 30 4 71 02 51
 info@raytek.de

Raytek United Kingdom

Milton Keynes, UK
 Tel: 44 1908 630800
 Fax: 44 1908 630900
 ukinfo@raytek.com

Raytek France

Palaiseau, France
 Tel: 33 1 64 53 1540
 Fax: 33 1 64 53 1544
 raytek@wanadoo.fr



© 2001 Raytek Corporation (2-5101/ Rev. C) 12/2001
 Raytek, DataTemp and the Raytek logo are registered trademarks,
 and Process Imaging Series, ES100 and MP50 are trademarks
 of Raytek Corp. Windows, Windows NT and Windows 2000 are
 registered trademarks of Microsoft Corp. Specifications subject to
 change without notice.

Raytek[®]